



LIGHTFACTORY V2 FIXTURE EDITOR USER GUIDE

V2.0

Copyright © 2004 - 2009 Dream Solutions Ltd

Auckland, New Zealand

LIGHTFACTORY FIXTURE EDITOR USER GUIDE

The software described in this book is furnished under a license agreement and may be used only in accordance with the terms of the agreement.

COPYRIGHT NOTICE

Copyright © 2004 - 2009 Dream Solutions Ltd.

All Rights Reserved.

This document may in whole or in part, be copied, photocopied, reproduced, translated or reduced to any electronic medium or machine-readable form. This document may NOT be modified in any way without prior consent in writing from DREAM SOLUTIONS LIMITED, of Ascot Way, Orewa, Auckland Region, New Zealand.

ALL EXAMPLES WITH NAMES, COMPANY NAMES, OR COMPANIES THAT APPEAR IN THIS BOOK ARE IMAGINARY AND DO NOT REFER TO, OR PORTRAY, IN NAME OR IN SUBSTANCE, ANY ACTUAL NAMES, COMPANIES, ENTITIES OR INSTITUTIONS. ANY RESEMBLANCE TO ANY PERSON, COMPANY, ENTITY OR INSTITUTION IS COINCIDENTAL.

DISCLAIMER

Every effort has been made to ensure the accuracy of this manual. However, DREAM SOLUTIONS LIMITED makes no warranties with respect to this documentation and disclaims any implied warranties of merchantability and fitness for a particular purpose. DREAM SOLUTIONS LIMITED shall not be liable for any errors or for incidental or consequential damages in connection with the furnishing, performance or use of this manual or the examples herein. The information in this document is subject to change without notice.

LIGHTFACTORY SOFTWARE LICENCE AGREEMENT

These terms and conditions (**Licence**) form a legally binding agreement between you (**Licensee**) and Dream Solutions Limited (**DSL**) of 18 Ascot Way, Orewa, Auckland Region, New Zealand.

The Licensee will be permitted to use the LightFactory software, encompassing all applications and databases (**Software**) only by accepting the terms of this Licence. Clicking on the "I Agree" button will constitute acceptance of the terms of this Licence. If you are not willing to enter into this Licence, the "Cancel" button should be clicked, and you must not install or otherwise download the Software.

Where the Licensee is not an individual then the agreement of the person accepting the terms of this Licence shall be deemed to be acceptance by the Licensee.

1. Intellectual Property

- 1.1 The Licensee acknowledges and agrees that all intellectual property rights, including copyright, relating to the Software are the sole property of DSL.
- 1.2 The Licensee acknowledges and agrees that all source code and form definitions relating to the Software are the sole property of DSL and may not be modified in any way.
- 1.3 The Licensee acknowledges and agrees that all enhancements, modifications or customisations, including associated source code and form definitions, made by or on behalf of the Licensee and relating to the Software, vest on creation in and are the sole property of DSL.
- 1.4 Subject to clause 2.2, the Licensee does not obtain, either under this Licence or by reason of use of the Software, any right to copy the Software, or any right to use the Software after the Licence has terminated.

2. Licence

- 2.1 The Licensee is granted a non-exclusive, non-transferable, non-sublicensable licence to install and use the Software for the Licensee's own internal business purposes, provided that the Licensee pays the charges for the Licence (as published at

http://www.lifact.com/prod_pricing.html).

- 2.2 The Licensee is permitted to make one copy of the Software for backup purposes only.
- 2.3 The Licensee will during the continuance of the Licence:
 - 2.3.1 use the Software only as allowed for under this Licence and will not resell, rent, sub-license or otherwise make the Software available to any person or entity;
 - 2.3.2 subject to clause 2.2 or as permitted by applicable law, not copy, decompile, adapt, modify or reverse engineer the Software or allow it to be copied, decompiled, adapted, modified or reverse engineered by any third party, or modify the source code or form definitions in any way;
 - 2.3.3 not remove or alter any copyright or other proprietary notice contained in the Software;
 - 2.3.4 effect and maintain adequate security measures to safeguard the Software from access or use by any unauthorised person; and
 - 2.3.5 retain the Software and all copies of it under the Licensee's effective possession and control.

3. Assignment

- 3.1 The Licensee may not transfer the benefit of this Licence or the Software to any person or entity without the prior written consent of DSL. DSL may assign or transfer this Licence without the Licensee's consent.

4. Warranty

- 4.1 DSL warrants that when the Software is used with reasonable skill and care it will operate in accordance with the functional specifications (published at http://www.lifact.com/prod_spec.html). This warranty is valid for a period of ninety (90) days from the date of purchase.
- 4.2 The warranty in clause 4.1 is void if the Licensee is in breach of

any term of this Licence, or if failure of or defect in the Software has resulted from accident, abuse, misapplication, abnormal use or use other than in accordance with the specifications outlined on the website (http://www.lifact.com/prod_spec.html).

- 4.3 If a significant defect in the Software is found in the ninety (90) day warranty period, the Licensee may return the Software for a refund on giving written notice to DSL. The Licensee is not entitled to any updates, patches, fixes or upgrades in respect of the Software unless DSL in its absolute discretion otherwise agrees. DSL may in its discretion provide limited email and telephone support in respect of the Software but, following the 90 day warranty period, reserves the right to charge the Licensee for the provision of support.
- 4.4 Subject to clause 4.1, all conditions, warranties, terms, representations and undertakings, whether express or implied, statutory or otherwise, in respect of the Software are hereby excluded to the extent permitted by law. In particular, but without limitation, DSL disclaims, to the greatest extent permissible by law, any warranty or representation, either express or implied, of the Software's performance, non-infringement or fitness for a particular purpose or process.

5. Limitation of Liability

- 5.1 To the extent permissible by law, in no event will DSL be liable to the Licensee for any direct, special, incidental, indirect or consequential loss, damage, cost or expense suffered or incurred by the Licensee or any third party in connection with the Software.
- 5.2 The entire liability of DSL in connection with the Software will not exceed the price paid by the Licensee for the Software.

6. Term and Termination

- 6.1 This Licence will remain in effect until terminated.
- 6.2 DSL may terminate this Licence on ninety (90) days' written notice to the Licensee or immediately if the Licensee fails to comply with any term of this Licence.

- 6.3 Upon termination by DSL, the Licensee will be required to return the Software to DSL and confirm in writing that no copies of the Software have been made and retained.
- 6.4 The provisions of clauses 4, 5, 7 and 8 of this agreement shall survive termination of this Licence for whatever reason.

7. Governing Law

- 7.1 This Licence shall be governed by the laws of New Zealand and is subject to the exclusive jurisdiction of the Courts of New Zealand.

8. Miscellaneous

- 8.1 This Licence records the entire understanding and agreement between the Licensee and DSL. This Licence supersedes all previous understandings or agreements (whether written, oral or both) between the Licensee and DSL.
- 8.2 DSL reserves the right to amend the terms of this Licence on sixty (60) days' written notice, posted on DSL's website. Continued use of the Software by the Licensee following the sixty (60) day notice period will constitute acceptance of the amended terms of the Licence, and the provisions of this Licence will be deemed to be altered accordingly.
- 8.3 Any waiver by DSL of its rights or remedies under this Licence will be effective only if it is recorded in writing and signed by DSL. If the waiver related to a breach of any provision of this Licence, this will not (unless stated otherwise) operate as a waiver of any other breach of that provision. No waiver of any breach, or failure to enforce any provision, of this Licence at any time by DSL will in any way affect limit or waive DSL's right to subsequently require strict compliance with this agreement.
- 8.4 If the Licensee has any dispute with DSL in connection with this Licence or the Software, it must give written notice to DSL and may submit the dispute for mediation by a single mediator nominated by the President for the time being of the New Zealand Law Society. In the event of any submission to mediation:

- 8.4.1 the mediator will not be acting as an expert or as an arbitrator;
 - 8.4.2 the mediator will determine the procedure and timetable for the mediation; and
 - 8.4.3 the parties will share equally the cost of the mediation.
- 8.5 The Licensee agrees that it will not issue any legal proceedings against DSL relating to any dispute, unless the Licensee has first taken all reasonable steps to comply with clause 8.4. Nothing in this Licence will prevent DSL from taking any steps it deems in its sole discretion necessary or desirable to protect its intellectual property rights or otherwise to enforce any of its rights under this Licence.
- 8.6 If any provision of this Licence is or becomes invalid or unenforceable, that provision will be deemed deleted from this Licence. The invalidity of unenforceability of that provision will not affect the other provisions of this Licence, all of which will remain in full force and effect to the extent permitted by law, subject to any modifications made necessary by the deletion of the invalid or unenforceable provision.

CONTENTS

Contents	1
Overview	3
Concepts	4
DMX System	4
Attributes	6
Intelligent Fixtures	7
Start address	7
Known types of attributes	7
Starting the Fixture Editor	10
Search	12
Editing a fixture	13
Name, Mode and Short Name	13
Fixture Type	14
Notes	14
Alternative Names (Visualiser)	15
Fixture Image	15
Attributes Overview	15
Adding a new attribute	16
Revert	17
Testing a fixture	17
Shifting the order of the attributes	17
Deleting an attribute	18
Attribute Grouping	18
Attribute Reference	19
Dimmer	20
Generic	20
Movement (Pan / Tilt)	26
Position (X/Y/Z)	27
Dynamic Colour	28
Framing	30
Rotation	32
Wheel Groups	35
When 2 attributes share the same offset	37
Creating a new fixture	38
Other options	41
Importing fixtures	41

Deleting a fixture	41
Save	41

OVERVIEW

LightFactory is a unique PC based lighting controller that combines the best of traditional lighting control with advanced features only available with the power of a PC.

The LightFactory fixture editor is a separate application that is used to build and modify fixture definitions used by the software. LightFactory comes with an extensive list of fixtures and devices from a number of manufacturers that you can modify or use as a bases to build your own fixtures.

This user guide will take you through all of the features of the fixture editor and show you how to use it to its fullest potential.

CONCEPTS

This section covers some basic terms used in building a fixture profile.

DMX SYSTEM

DMX 512 is an EIA-485 based communications protocol and is the standard protocol by which lighting control desks communicate with lighting equipment.

The DMX 512 protocol is a stream of data that is sent via a cable system connected between the data transmitter (LightFactory) and a data receiver, which could be anything ranging from a basic light to intelligent lights, smoke machines, etc.

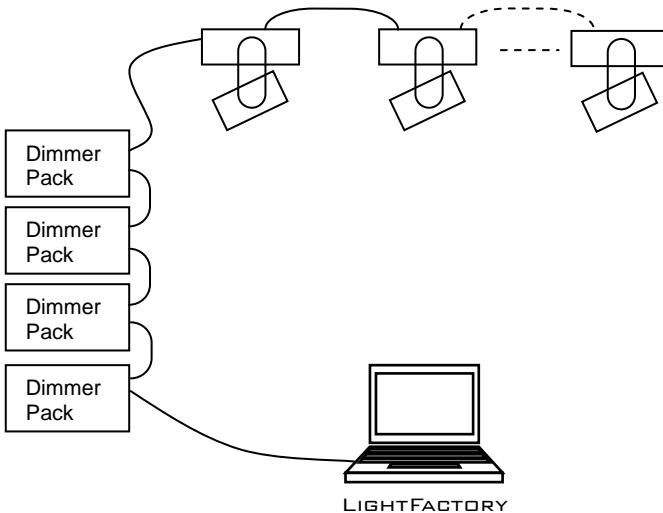

LightFactory uses the standard DMX 512 protocol to communicate with the equipment it controls. DMX is connected to the LightFactory software via either a USB-DMX connection (See **"Error! Reference source not found."** on page **Error! Bookmark not defined.** for more about USB) or Ethernet to DMX converters.

Developed by the Engineering Commission of USITT, the standard started in 1986, with subsequent revisions in 1990 leading to USITT DMX512/1990. In 1998 ESTA began a revision process to develop the standard as an ANSI standard, including a Public Review

process. The revised standard, known officially as "Entertainment Technology — USITT DMX512–A — Asynchronous Serial Digital Data Transmission Standard for Controlling Lighting Equipment and Accessories", was approved by ANSI in November 2004. This current standard is also known as "E1.11, USITT DMX512–A", or just "DMX512-A", and is maintained by ESTA.

DMX512 is unidirectional and does not include automatic error checking and correction, so it is not safe to use for applications involving life safety, such as controlling pyrotechnics or laser lighting display where audience or performer safety is involved.

DIMMERS

In the simplest terms, a dimmer is a physical apparatus used for controlling the intensity of a basic light.

A dimmer can be fully on, fully off, or somewhere in-between. The setting of a dimmer is referred to as the DMX value. DMX values range from zero to 255. A value of zero means the light is off, and 255 means the light is fully on. By adjusting the DMX value up and down, the intensity of the light increases and decreases.

Basic dimmers come as units known as Dimmer Packs, usually made up of 4 to 24 dimmers per pack.

For example, a 12-pack consists of 12 dimmers. Each dimmer is a physical plug on that 12-pack, each of which operates independently of the other 11.

DMX VALUE

The setting of a dimmer is referred to as the DMX value. DMX values range from zero to 255. A value of zero means the light is off, and 255 means the light is fully on. By adjusting the DMX value up and down, the intensity of the light increases and decreases.

DMX UNIVERSE

A DMX universe consists of 512 DMX dimmers. In the case of the LightFactory system, this translates to one USB-DMX box. If more dimmers are required, simply add another USB-DMX box or use one of the DMX to Ethernet options.

ATTRIBUTES

An attribute is a function of a device connected to the DMX network that can be controlled by the lighting console. Some examples of attributes include: Pan, Tilt, Colour, Gobo, Focus, Frost, Zoom, Intensity etc.

There is no fixed list of attributes used by the lighting industry as new fixtures that do new things add to the list daily. There are some very common attributes such as the ones listed in the example above. Below is a slightly more complete list of common attributes;

Intensity	Pan	Tilt	Colour	Gobo
Zoom	Focus	Iris	Frost	Diffusion
Edge	Shutter	Strobe	Rotation	Speed
Time	Effect	Macro	Twinkle	Animation
Shape	Mode	Control	Prism	Shutters

Attributes are typically controlled via the same DMX signal described above. Each attribute is assigned an offset from the start address to control it. For example if we have a moving light that has intensity, pan and tilt only then the intensity may have offset 0, pan offset 1 and tilt offset 2. This does not mean that they respond necessarily to DMX address 0, 1 and 2 but rather the attributes respond to start address plus their offset.

The fixture reads the DMX data and uses the value at the start address plus the offset to control that attribute.

Fixture attributes can be 8-bit or 16-bit. This essentially determines how finely a property can be controlled. A 16-bit attribute uses 2 DMX dimmers to control the value to be set. Instead of 255 value levels the attribute can have $255 * 255$ values.

A 16-bit attribute can be more finely controlled than an 8-bit attribute. For example, 16-bit pan and tilt enables the fixture to be moved much more slowly than 8-bit pan and tilt.

8-bit – has 255 settings, zero to 255 for the attribute.

16-bit – has 65535 ($255 * 255$) settings, zero to 65535 for the attribute.

INTELLIGENT FIXTURES

Fixtures that have multiple attributes to be controlled from the lighting desk are typically called Intelligent fixtures. It is also common to refer to these fixtures as moving lights because in most cases we are referring to fixtures that have a pan and tilt control. However it is important to remember that this is not the case for all intelligent fixtures. A smoke machine is an example of an intelligent fixture that does not have any of the more common attributes.

The main purpose of the LightFactory fixture editor is to teach the software about the offsets of a specific Intelligent fixture by defining a "Fixture Profile".

START ADDRESS

Intelligent fixtures require setting a start address so that they can be uniquely controlled via the DMX system.

Some fixtures refer to this as the DMX address of the fixture or the "Start Channel". The start address is the first channel used to receive control messages from the lighting console. For independent control, each fixture must be assigned its own start address. Two fixtures may share the same address however the behaviour of their attributes will be identical.

KNOWN TYPES OF ATTRIBUTES

To make using intelligent fixtures easier LightFactory has a number of known types of attributes. This allows the software to provide an easy user interface specific to these attributes. When adding attributes to a fixture profile you must decide on one of these master types.

DIMMER

Because the dimmer on a fixture is the traditional way to control light output this attribute is given its own special type. There is not really any difference between the dimmer type and the generic type described below except that LightFactory uses this attribute as the main control when turning a light on or off.

GENERIC

All attributes that do not fall into the other types should be set to "Generic". This is the attribute type you will use most frequently when creating fixtures.

MOVEMENT (PAN, TILT)

If the fixture supports a pan and tilt type movement such as a moving head or moving mirror light then this attributes should be used to control those attributes.

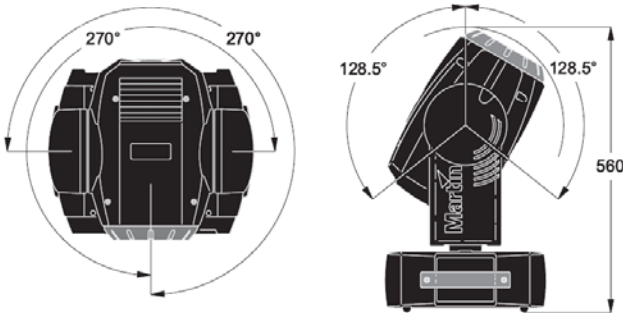

POSITION (X, Y, Z)

Similar to the pan and tilt control the position attribute type is used when an extra degree of freedom is provided. The most common use for this attribute type is a moving camera.

DYNAMIC COLOUR

Many intelligent fixtures provide the ability to set the colour of the light dynamically by mixing base colours together. The most common mixing system in moving lights is Cyan, Magenta and Yellow. This is referred to as a subtractive system as by removing cyan, magenta or yellow from a white light source we can produce virtually any colour we require.

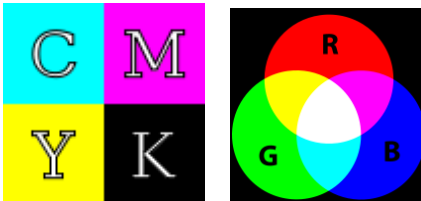

Alternatively a red, green and blue colour mixing system such as used in an LED fixture adds the various colours to produce the desired colour.

ROTATION

Rotation controls are typically linked to a generic control as it provides the ability to rotate another attribute.

You can use a rotation control independent of other attributes.

Rotation controls allows you to identify to the software how to achieve indexed rotation, clockwise rotation, anti-clockwise rotation and how to stop the rotation.

FRAMING

Framing shutters are typically complicated to control in lighting consoles as they require a lot of DMX channels (min 8) to control a set of shutters. If framing shutters are setup using this attribute type LightFactory will provide a graphical representation of the shutter system, significantly simplifying the control.

STARTING THE FIXTURE EDITOR

Unlike version 1 of LightFactory the fixture editor for version 2 is a separate application and not part of the main program. There is no additional installation required to use the Fixture editor.



Note: If you have not done so already you must install LightFactory to use this application.

The fixture editor can be started directly within LightFactory or from the windows “Start” menu.

To start the fixture editor from LightFactory click on the “Extra’s” menu in the main window and select “Edit Fixture Library” from the resulting menu.

To start the fixture editor from the windows “Start” menu find the LightFactory V2 icon group and select “Fixture Editor” from the resulting menu.

Once started a small dialog box will be shown indicating that the program is loading the list of fixtures. When finished the main window will appear

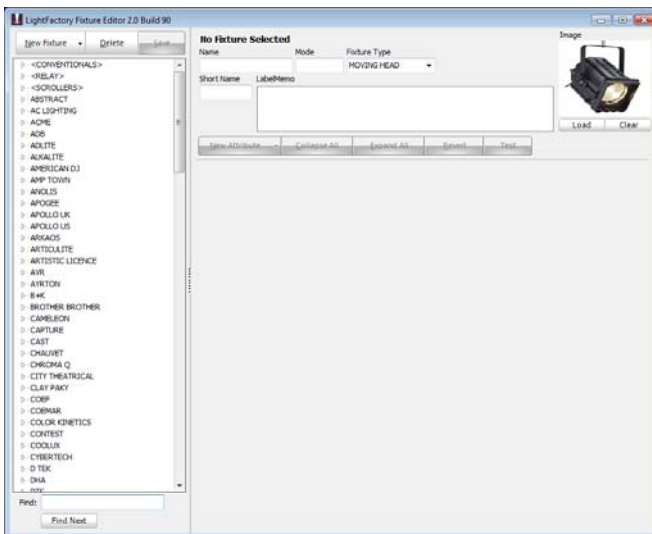

Figure 1: Fixture Editor Main Window

On the left hand side of this window is a tree structure that will appear as a list of manufacturers. By clicking on the small triangle or plus symbol to the left of the manufacturers name the list of fixtures will be shown.

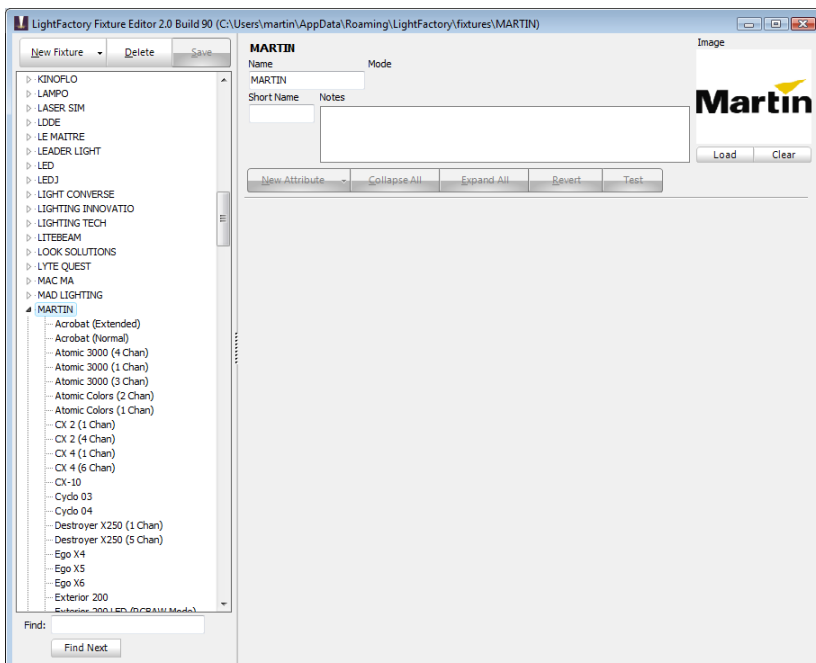

Figure 2: Expanding a manufacturer to show fixtures

In the above example the “Martin” brand has been expanded to show all of the fixtures made by that manufacturer. This also acts as selecting the manufacturer and thus showing the manufacturer information in the right hand portion of the window.

Use the fields in the top right of this window to edit information about this manufactures. You can also assign a logo for quick reference.

SEARCH

Below the list of manufacturers and fixtures is a search box that will allow you to find a fixture by its name without having to use the tree control.

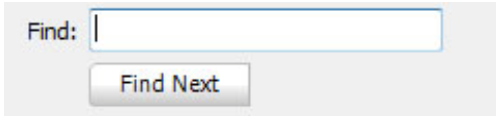

As you type the name of the fixture into the box provided the software will find the first fixture that matches the characters typed. To find the next matching fixture press the "Find Next" button below the search box.

If no fixture can be found matching the search criteria then a red explanation mark will be displayed to the right of the search box.

If a matching fixture is found the tree control will automatically scroll to the location and select the fixture. The right hand side of the window will display the fixture information.

EDITING A FIXTURE

Once a fixture is selected all of the information stored in the profile will be displayed in the right hand side of the window (Fixture panel).

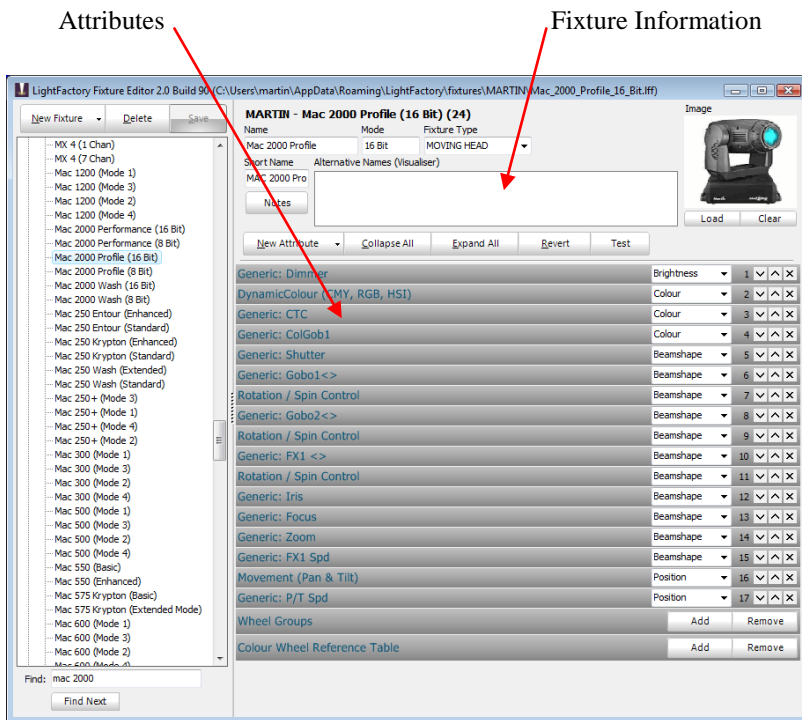

Figure 3: Editing an existing fixture

At the top of the fixture panel is the general fixture information including its name, type and picture.

NAME, MODE AND SHORT NAME

The fixture is generally identified by the name and mode. Not all fixtures have multiple modes and it is fine to leave the mode field

blank. If the fixture does have more than one mode then this field should be used to identify it.

The short name is a name the software can use when space is limited in the interface. This field will be automatically populated when the fixture is created but can be changed if the automatically created name does not describe it accurately.

FIXTURE TYPE

By providing the fixture type information LightFactory can display more meaningful information when controlling the fixture.

Choose the fixture type from the drop down list provided.

NOTES

Additional information can be stored about the fixture in the notes window by pressing the “Notes” button.

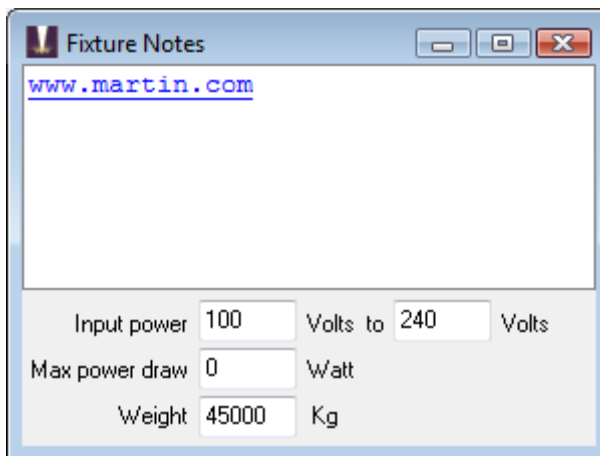

Figure 4: Fixture Notes

Fixture notes can be used to store support information such as the web site of the manufacturer or the phone number of a local support agent. There is no limit to the size of the text that can be stored in this field.

The fixture profile can also store information about the power used by the fixture and the physical weight. This information is intended for future features in LightFactory.

Once you have finished editing the notes you can close the window by clicking on the “X” in the top right hand corner. The notes entered will automatically be added to the fixture you are editing.

ALTERNATIVE NAMES (VISUALISER)

The alternative names field is primarily used to store the names that visualisers use to reference the fixture. When auto patching is used with your visualiser LightFactory needs to link the fixture being patched with a fixture in the visualiser.

When a fixture is patched from a visualiser that cannot be found in the LightFactory library a dialog will appear asking you to select the fixture from a list. Once chosen from the list it will store that name in the “Alternative Names” field and you will see it shown here.

FIXTURE IMAGE

The small image of the fixture will be shown in the channel display for quick visual reference. To change the image show click on the “Load” button below the picture. A standard windows image dialog will appear to allow you to select a picture from the system. Regardless of the size image you select it will be resized down to the thumbnail size shown.



To clear the current picture and revert back to the default image (Selecon Fresnel) click on the “Clear” button below the image.

ATTRIBUTES OVERVIEW

Below the fixture information is the fixture attributes in collapse form. Because there is a lot of information to be displayed for some fixtures the attributes can be expanded or collapsed to show or hide their information. This allows you to see the fixture at a glance without being overwhelmed by all of the information.

To expand an attribute double click on the heading or click the “Expand all” button at the top of the attribute section. At any time you can collapse all of the attribute rows by clicking on the “Collapse All” button.

Attribute information for the dynamic colour control

Double click on the heading here to expand the attribute

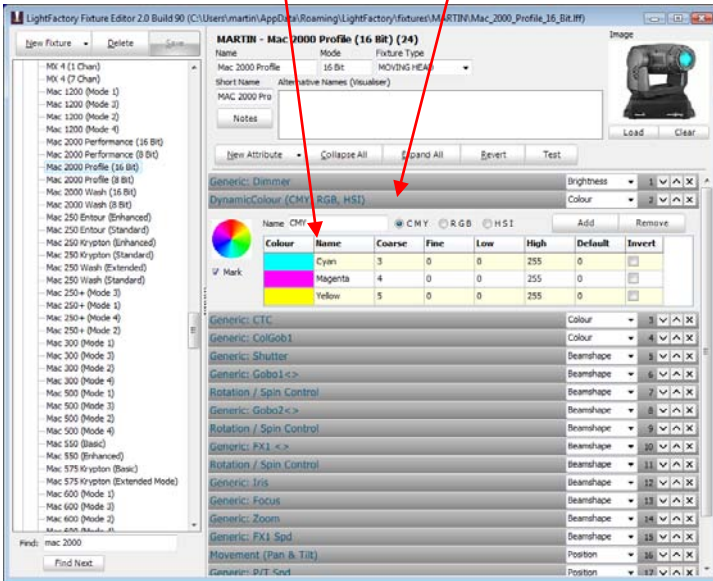

Figure 5: Fixture editing, expanding an attribute

In the above example we have expanded just the Dynamic Colour control and we see that this is a CMY colour mixing.

ADDING A NEW ATTRIBUTE

To add an attribute to the fixture click on the “New Attribute” button just above the list of attributes. A drop down menu will appear with the list of available attribute types.

Select the most appropriate known attribute type to LightFactory and the new attribute will appear at the end of the list.

For more information about the different attributes and the information that is stored for each type see the next section “Attribute Reference” on Page 19.

REVERT

Above the attribute list is the “Revert” button. This can be used at any time to discard the changes you have made and revert back to the saved fixture.

TESTING A FIXTURE

To see what the fixture will look like in the attribute control window in LightFactory click on the “Test” button above the attribute list. The same fixture control window that appears when using the channel display in LightFactory will be shown. Changes made to this window will not be sent to any connected fixtures. To test the fixture connected to the DMX system you must patch it into LightFactory.

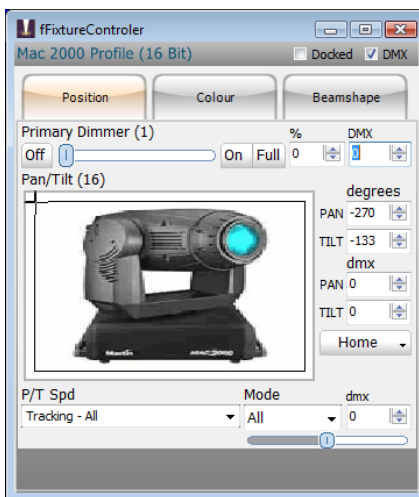

SHIFTING THE ORDER OF THE ATTRIBUTES

You can move the attributes up and down the order by pressing the up or down arrows on the right hand side of the attribute heading bar.





Note: The order that the attributes appear in this list is not related to the offset order and will not affect the way the fixture is controlled. Re-ordering the attributes will only change the way they are displayed in LightFactory.

DELETING AN ATTRIBUTE

You can remove an attribute by clicking on the “X” at the far right of the attribute title bar.



ATTRIBUTE GROUPING

To the right of the attribute title bar is a drop down combo box that is used to put the attribute into groupings.

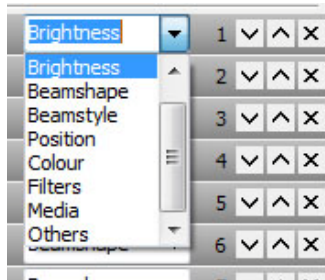

The groupings are a critical part of using LightFactory as they allow filtering when recording cues, groups or palettes. For example you may want to update a cue but only update the colour information. When you press the update button in LightFactory you will see a list of attribute groups to choose from. By checking and unchecking the groups the software will filter what gets recorded.

Select the group that attribute should be a part of using the drop down control.

ATTRIBUTE REFERENCE

This section will go into detail about setting up the various types of attributes.

- Dimmer
- Generic
- Movement (Pan / Tilt)
- Position (X/Y/Z)
- Dynamic Colour
- Framing
- Rotation

The key field in all of the attributes described below is the OFFSET. The offset defines the location from the start address for controlling the attribute.

An offset of 0 will turn the attribute off as this is considered the “undefined value”. The offset of the first attribute listed should be 1. The maximum offset value is 512.

If the attribute is for 16bit control you will need to supply two offset values. The first offset defines the course control of the attribute while the second offset defines the fine control. When LightFactory is setting a value for the attribute it will automatically calculate the values to send to the course and fine control parameters.



Note: If the offset given to you is not defined as coarse or fine then coarse should be used as the default.

Note: The coarse field in the offset can sometimes be referred to as the “High Byte” and the fine referred to as the “Low Byte”.

DIMMER

The dimmer control has almost all of the same fields as a generic control item. The only difference is that the “known type” field cannot be changed. Refer to the generic attribute for more details.

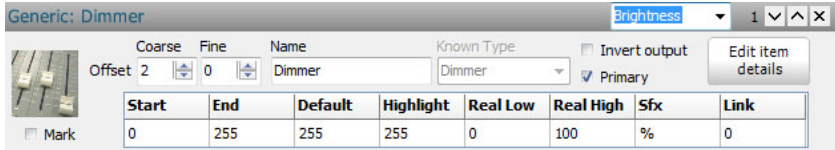

Figure 6: Attribute Reference, Dimmer

GENERIC

The generic control is the most commonly used attribute control type. If you are unsure what type of control to use then the generic should be considered the default.

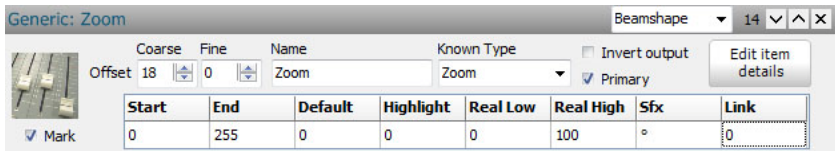

Figure 7: Attribute Reference, Generic

Offset (Coarse & Fine) – The offset defines the address relative to the start address that will control the attribute. This is the only mandatory field for the attribute to work in LightFactory. If the attribute is for 8bit control then only the “coarse” field needs to be populated. If you are adding a 16bit attribute then the “Fine” field must also be used.

Name – Although not mandatory for the attribute to work the name is the second most important field. This is the reference that will be used to label the attribute within LightFactory. Use a meaningful name or preferably the name given in the fixtures user manual.

Known Type – If the attribute type is listed in this drop down box then select it from the list. This will allow LightFactory to present information in a more meaningful way.

Invert Output – For some attribute the output may need to be reversed to make it easier to use. For example some fixtures have the dimmer at full when the value is at 0 and off when the value is at full. Use the invert output check box to correct this behaviour. The inverting will be done at the final output stage of the DMX processing in LightFactory and will be completely transparent to your use of the attribute.

Primary – Use the primary check box to mark this as the main attribute to use if more than one attribute exists of the same type. This is used when the software is controlling the fixture using the generic model. Under generic control the software does not know the specific attribute it will talk to and so must find the first available. This flag will help LightFactory to identify the main control of this type. This flag will be turned on by default and should remain on if you are unsure.

Mark – Auto marking is a very useful feature when programming a show with moving lights. Previously called “Prefetch” in version 1 of LightFactory, Marking allows the fixture to be automatically setup with the attributes required for the next cue while the fixture is off in the current cue. See the main user guide for more information about this feature.

The flag in the fixture definition can be used to determine if this attribute should be marked when requested. As a general rule all attributes should have this flag set except for the dimmer.

Start – The start field defines the first value used by the attribute in its output. If a fixture uses the same offset for more than one attribute then you will need to set the range that this attribute uses for control. For more information see the section “When 2 attributes share the same offset” on Page 37.

End – The end field defines the last value used by the attribute in its output.

Default – Use this to define the default DMX value that will be used. The default value will be used when a fixture is “Homed” or reset.

Highlight – The highlight value is normally set to the same value as the default. This value is used when the fixture is put into a highlight state in LightFactory.

Real Low – The real world low value defines how the value is displayed in the fixture control.

Real High – The real world high value defines how the value is displayed in the fixture control.

Sfx – The suffix is generally a character that is placed after the value to identify its type. The combination of the real low, real high and the suffix defines the real world display of the underlying DMX data. For example if the attribute being setup is for zoom then we typically refer to the beam angle in degrees. If the fixture is capable of a zoom range of 20 through to 45 degrees then the real low value is 20, the real high value is 45 and the suffix is degrees (°).

Link – The link field is used in conjunction with the rotation controls and allows you to link a generic chooser such as a gobo selection with the appropriate rotation for that gobo. When linked the rotation control is able to change the item selection and the item selected is able to change the rotation control. For example some fixtures allow you to select gobos in either indexing or continuously rotation mode. When you select the indexing gobos then the rotation control will show indexing options. If you select a rotating gobo then the rotation control will change to show clockwise and anticlockwise rotation options.

EDITING ATTRIBUTE DETAILS

For attributes such as zoom or focus the control only needs to select a numerical value to set the output but for other attributes such as gobos or colour wheels we want to be able to choose specific items from a pick list. LightFactory allows you to define the static list of items that can be selected for this attribute. The software will still allow specific DMX values to be used but the primary control will be for item selection.

To edit the list of static items click on the “Edit Item Details” button to the right of the generic attribute setup. A new window will pop up near the attribute you are currently editing.



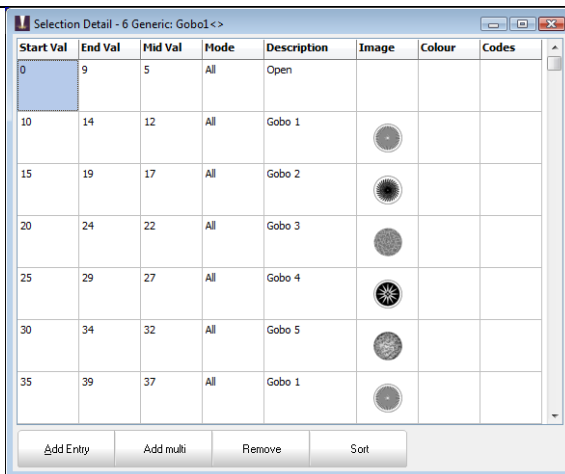

Figure 8: Generic Attribute Details Window

Add Entry – To create a new line or item in the list click on the “Add Item” button along the bottom of the window. The new line will appear with the default values entered into each of the fields.

Add Multi – To create several entries at once click on the “Add Multi” button. A dialog will appear allow you to specify the range for the items and how many items you want to create.

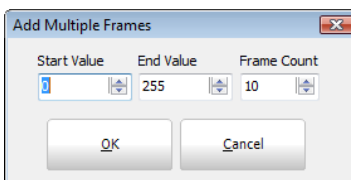

Figure 9: Generic item details, Add Multi dialog

Click “OK” to confirm the operating and create the entries in the table.

Remove – To delete an entry in the item list select it by clicking anywhere on the desired line and pres the “Remove” button.

Sort – When this window is opened the list of items will be sorted by the start value. As you edit the information the list may become unsorted. This is designed to allow you to quickly edit the information without seeing the cursor jump around the list. To re-sort the items click on the “Sort” button.

Entered as 8 bit – If the attribute is setup for 16 bit control then a check box is shown titled “Entered as 8bit”. If this is checked then you can enter the data into the start, end, and mid vales as a number between 0 and 255 and the software will automatically convert the number in a value between 0 and 65535.

Column Descriptions

Start Value – The start value is the first DMX value used by this item in the list.

End Value – The end value is the last DMX value used by this item in the list.

Mid Value – The mid value is also used as the default value when the item is chosen from the selection list in LightFactory. It should typically be the value half way between the start and end values.

Mode – Use the mode to tell the software more information about this item. If the item is for index rotation, continuous rotation, shake or any other effect it can be entered into this field. You can enter any text into the mode field however there are reserved modes that can be chosen from the drop down menu that when linked to a rotation control will provide enhanced control.

Description – This is a free form text field that can be used to enter any description of the item.

Image – To display an image associated with the item (e.g. a gobo or effect wheel) select it by clicking on the image field. As soon as you click on this field a file dialog will appear to select the image from your file system. You can also past images into the item from the windows clipboard using control-v.

Colour – It the item has a colour associated with it you can choose the colour by clicking on the colour field. As soon as you click on the field the LightFactory colour chooser will be displayed to allow you to select the colour.

Codes – The codes field is a free form text field is hold additional information about the item. This field is not currently used by LightFactory but is intended for future versions. The intended use for this field is to hold information such as a code to identify the colour or gobo against an industry standard.

Right Click Menu

Right clicking on the item detail list will pop up a menu with further options for editing the data.

Populate Mid Values – If the DMX charts provided do not have the mid values for each of the items you can easily populate the list automatically using the option.

Clear Mid Values – Use this option to clear out all of the mid values from the list.

Populate End Values – If you are only given the start values you can automatically populate the end values using this option. The end value will be one less than the next start value.

Calculate start and end from mid values – If you are only given mid values by the DMX charts you can use this option to automatically populate the start and end values. The start and end values will become the mid values between the mid points.

Clear Image – Removes the image currently assigned to the selected item.

MOVEMENT (PAN / TILT)

The movement control combines the two attributes of pan and tilt into a single control. The two attributes are linked into a simple cross hair control that can be manipulated in a 2D space.

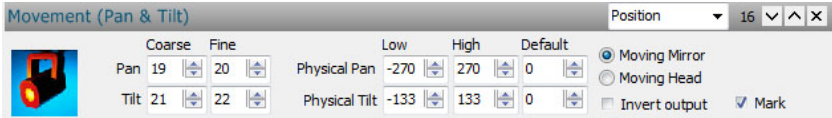

Figure 10: Attribute Reference, Movement

Coarse & Fine – The offset defines the address relative to the start address that will control the attribute. This is the only mandatory field for the attribute to work in LightFactory. If the attribute is for 8bit control then only the “coarse” field needs to be populated. If you are adding a 16bit attribute then the “Fine” field must also be used. Use the appropriate field for pan and tilt.

Physical pan & Tilt

Low – The lowest physical range of the attribute in degrees.

High – The highest physical range of the attribute in degrees.

Default – The default value for the attribute in degrees.

Invert Output – Check this option to invert the output of the pan and tilt controls.

Mark – Auto marking is a very useful feature when programming a show with moving lights. Previously called “Prefetch” in version 1 of LightFactory, Marking allows the fixture to be automatically placed into position for the next cue while the fixture is off in the current cue. See the main user guide for more information about this feature.

Moving Mirror / Moving Head – Specifying the type of moving light tell the software more about the fixture and it can use this information to make assumptions about how fast the fixture can move.

POSITION (X/Y/Z)

The position control is very similar to the movement control but adds an additional degree of freedom (attribute). The three attributes are linked into a simple control that can be manipulated in a 3D space.

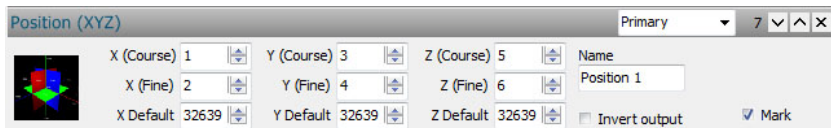

Figure 11: Attribute Reference, Position

Coarse & Fine – The XYZ offsets define the address relative to the start address that will control the attributes. This is the only mandatory field for the attributes to work in LightFactory. If the attribute is for 8bit control then only the “coarse” field needs to be populated. If you are adding a 16bit attribute then the “Fine” field must also be used. Use the appropriate field for X, Y and Z parameters.

Default – Use the default field to specify the DMX value that will be used when the fixture is sent to its home position.

Invert Output – Check this option to invert the output of the pan and tilt controls.

Mark – See the description of Mark in the other attribute types.

DYNAMIC COLOUR

The dynamic colour control is used to define how colour mixing occurs in the fixture. Colour mixing allows the fixture to produce any desired colour by mixing various fixed colours. LightFactory supports 3 different primary colour mixing systems but also allows you to add any number of additional colours that the fixture may support.

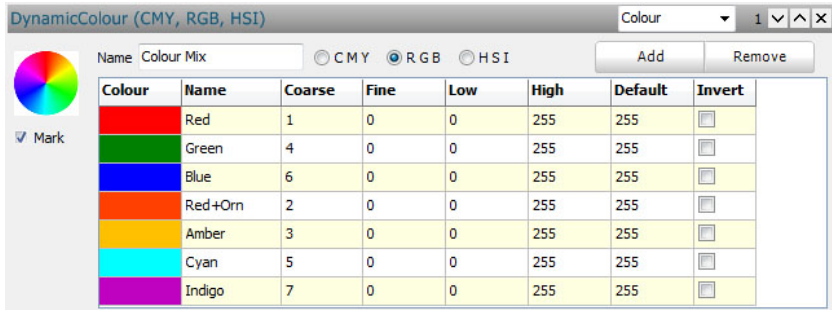

Figure 12: Attribute Reference, Dynamic Colour

PRIMARY COLOUR MIXING MODEL

CMY – Refers to Cyan, magenta and yellow. CMY is a subtractive colour model.

RGB – Refers to Red, Green and Blue. RGB is an additive colour model.

HSI – Refers to Hue, Saturation and Intensity. HSI represents points in an RGB colour model that attempt to describe perceptual colour relationships more accurately than RGB, while remaining computationally simple.

Depending on primary model chosen the first three lines in the grid above will be predefined. You cannot change or remove the first three colours.

To add or remove colours in the system use the “Add” or “Remove” buttons above the colour grid. As a colour line is added or removed from the grid the frame will automatically resize to show all of the lines.

PARAMETERS

Colour – Click on the colour column to select the colour from the standard LightFactory colour chooser. The colour chosen will be used in the calculations when moving between colour spaces in the fixture control.

Name – Use the name field to provide a meaningful text description of the colour.

Offset (Coarse & Fine) – The offset defines the address relative to the start address that will control the attribute. This is the only mandatory field for the attribute to work in LightFactory. If the attribute is for 8bit control then only the “coarse” field needs to be populated. If you are adding a 16bit attribute then the “Fine” field must also be used.

Low – This is the first value used by the attribute in its output.

High – This is the last value used by the attribute in its output.

Default – Use this to define the default DMX value that will be used. The default value will be used when a fixture is “Homed” or reset.

Invert Output – Check this option to invert the output of the colour.

Mark – See the description of Mark in the other attribute types.

FRAMING

The framing control is used to define up to 9 different attributes into a single control. The framing shutters on a moving light are typically difficult to control due to the large number of parameters to modify. By defining the framing into this special type LightFactory is able to provide a graphical interface without having to work with the underlying attributes used to make the framing shape.

Framing / Shutters Beamshape ▾ 15 ▾ ^ X



Name

Framing 1

Position

Angle

Mark

	Ofs Coarse	Ofs Fine	R Start	R End	Default	Invert
Position 1a	16	0	0	255	0	<input type="checkbox"/>
Position 1b	17	0	0	255	127	<input type="checkbox"/>
Position 2a	18	0	0	255	0	<input type="checkbox"/>
Position 2b	19	0	0	255	127	<input type="checkbox"/>
Position 3a	20	0	0	255	0	<input type="checkbox"/>
Position 3b	21	0	0	255	127	<input type="checkbox"/>
Position 4a	22	0	0	255	0	<input type="checkbox"/>
Position 4b	23	0	0	255	127	<input type="checkbox"/>
Rotation	24	0	0	255	128	<input type="checkbox"/>

Figure 13: Attribute Reference, Framing

POSITION OR ANGLE

There are two different modes that the framing shutter system can be used in.

Position Mode - The shutter mechanism is comprised of four frame blades that move independently or in unison on two planes. Each blade has 2 controls that move each side of the blade in or out.

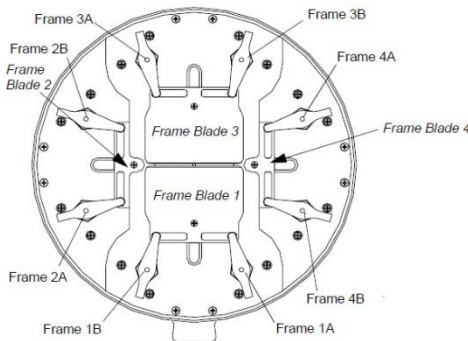

Angle Mode – The system comprises four shutter blades, each blade able to be swivelled and moved in or out. Each blade has 2 controls – one to move the position and the other to move the angle.

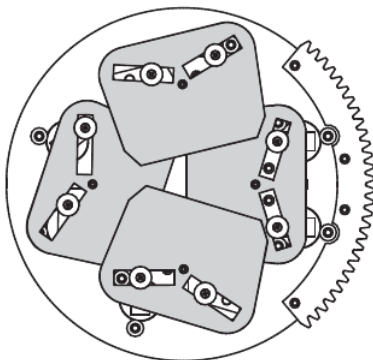

When the mode is changed for the attribute being edited every alternative row title will change. If position mode is used then the label will read “Position Xb”. For position mode each side of the blade is referred to as “A” and “B”. In angle mode the label will read “Angle X”.

Offset (Coarse & Fine) – The offset defines the address relative to the start address that will control the attribute. This is the only mandatory field for the attribute to work in LightFactory. If the attribute is for 8bit control then only the “coarse” field needs to be populated. If you are adding a 16bit attribute then the “Fine” field must also be used.

R Start – This is the first value used by the attribute in its output.

R End – This is the last value used by the attribute in its output.

Default – Use this to define the default DMX value that will be used. The default value will be used when a fixture is “Homed” or reset.

Invert Output – Check this option to invert the DMX output.

Mark – See the description of Mark in the other attribute types.

ROTATION

The rotation control defines special functionality for both indexed and continuous rotation. By defining rotation as this type special allowance can be made when switching between modes. If linked with a generic control (using the link field) the two attributes can provide the appropriate user interface for the item selected.

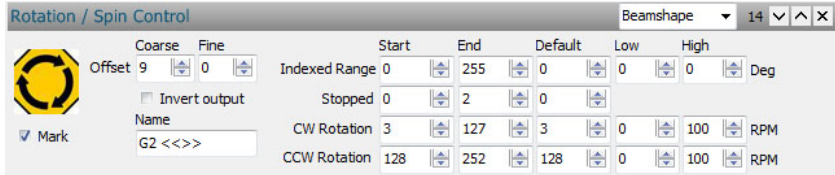

Figure 14: Attribute Reference, Rotation

Offset (Coarse & Fine) – The offset defines the address relative to the start address that will control the attribute. This is the only mandatory field for the attribute to work in LightFactory. If the attribute is for 8bit control then only the “coarse” field needs to be populated. If you are adding a 16bit attribute then the “Fine” field must also be used.

Invert Output – Check this option to invert the DMX output of the rotation control.

Name – Use the name field to provide a text description of the control. The rotation name should contain a description of what is being rotated.

INDEXED RANGE

Start – This is the first DMX value used by the attribute when in indexed mode.

End – This is the last DMX value used by the attribute when in indexed mode.

Default – Use this field to define the default DMX value that will be used when in indexed mode. The default value will be used when a fixture is “Homed” or reset.

Low – The real world low value defines the start angle for indexed rotation.

High - The real world high value defines the final angle for indexed rotation.

STOPPED

Start – This is the first DMX value used by the attribute when in continuous rotation mode and the rotation is stopped.

End – This is the last DMX value used by the attribute when in continuous rotation mode and the rotation is stopped.

Default – Use this field to define the default DMX value that will be used when in continuous rotation mode and the rotation is stopped.

CW ROTATION

Start – This is the first DMX value used by the attribute when in continuous rotation mode and the rotation is clockwise.

End – This is the last DMX value used by the attribute when in continuous rotation mode and the rotation is clockwise.

Default – Use this field to define the default DMX value that will be used when in continuous rotation mode and the rotation is clockwise.

Low – The real world low value defines the start rotation speed in RPM.

High - The real world high value defines the maximum rotation speed in RPM.

CCW ROTATION

Start – This is the first DMX value used by the attribute when in continuous rotation mode and the rotation is counter clockwise.

End – This is the last DMX value used by the attribute when in continuous rotation mode and the rotation is counter clockwise.

Default – Use this field to define the default DMX value that will be used when in continuous rotation mode and the rotation is counter clockwise.

Low – The real world low value defines the start rotation speed in RPM.

High - The real world high value defines the maximum rotation speed in RPM.

WHEEL GROUPS

At the bottom of the list of attributes is a title bar called “Wheel Groups” that is used to define the order that attributes appear on the physical wheel controls or external wing hardware.



Figure 15: Wheel controls on the Enttec Program Wing

LightFactory currently supports hardware with 3 wheels. Each line in the wheel groups table is a page on the hardware device that can be selected.

Wheel Groups				Add	Remove
Attribute Type	Wheel 1	Wheel 2	Wheel 3		
Position	2 (Dimmer)	19 (Pan)	21 (Tilt)		
Colour	3 (Cyan)	4 (Magenta)	5 (Yellow)		
Beam Shape	6 (CTC)	7 (ColGob1)	1 (Shutter)		
Beam Shape	8 (Gobo1<>)	11 (Gobo2<>)	14 (FX1 <>)		
Beam Shape	16 (Iris)	17 (Focus)	18 (Zoom)		
Beam Shape	24 (FX1 Spd)	23 (P/T Spd)			

Figure 16: Edit Fixture, Wheel Groups

Add a new page (line) by clicking on the “Add” button in the title bar of the wheel group configuration.

To remove the page click anywhere on the line to be removed then click on the “Remove” button.

For each page you should select the attribute type from the drop down menu. This is used to filter the wheel groups in LightFactory.

To set what each of the wheels controls enter the DMX offset of the attribute into the appropriate field of wheel 1, 2 or 3. As soon as the number is entered the assigned attribute name will appear so that you can ensure you have entered the correct number.

WHEN 2 ATTRIBUTES SHARE THE SAME OFFSET

If you encounter a fixture that has two features that both share the same offset number the recommended procedure is to create two attributes in LightFactory and assign the same offset to both. Use the range settings in each attribute to tell LightFactory that different DMX values control each attribute.

When using LightFactory the attributes will be applied on a latest takes precedence model. Meaning that the last attribute you modified will override the other attribute.

For example we may have a fixture that has the following definition for DMX offset 1.

Offset	Description	Details
1	Dimmer + Strobe	0 – 127 Dimmer 128 – 255 Strobe

In LightFactory we want to be able to use the dimmer without having to worry that if we go beyond 50% the light will start to strobe. Ideally we want to be able to control the strobe as if it was a separate attribute.

Below is how we can setup the fixture definition to achieve exactly that. The key fields are the start and end values for each attribute. Notice that the start value of the second attribute is after the end value of the first attribute.

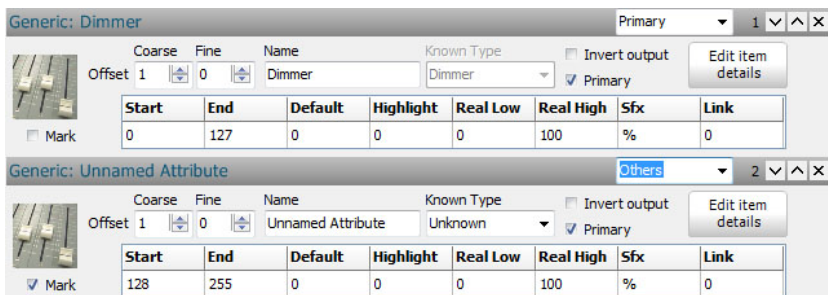

Figure 17: Shared attributes

CREATING A NEW FIXTURE

When creating a new fixture you will need the DMX chart for that fixture. This is typically located in the user guide that accompanied the fixture or in some case you may need to get the information from the manufacturer’s web site.

The following is from the Martin MAC 250 Krypton user manual and is a sample of what the DMX charts might look like;

MAC 250 Krypton DMX protocol

16 Bt (16 Bit Mode)	16 Ex (16 Bit Extended)	Value	Percent	Function	
<p>1</p> <p>¹If DMX Reset is disabled in the menu, a reset command can only be executed if the CTC filter is selected, the prism is on (not rotating) and the open gobo is selected.</p> <p>A 5 second delay can be given to the reset command from the fixture menu under <i>IRFS</i>.</p> <p>²If DMX Lamp Off is disabled in the menu, a lamp off command can only be executed if the CTC filter is selected, the prism is on (not rotating) and the open gobo is selected.</p>		0 - 19 20 - 49 50 - 72 73 - 79 80 - 99 100 - 119 120 - 127 128 - 147 148 - 167 168 - 187 188 - 190 191 - 193 194 - 196 197 - 199 200 - 202 203 - 207 208 - 217 218 - 227 228 - 237 238 - 247 248 - 255	0 - 7 8 - 19 20 - 28 29 - 31 31 - 39 39 - 47 47 - 50 50 - 58 58 - 65 66 - 73 74 - 75 75 - 76 76 - 77 77 - 78 78 - 79 80 - 81 82 - 85 85 - 89 89 - 93 93 - 97 97 - 100	<p>Shutter, strobe, reset, lamp on/off</p> <p>Shutter closed</p> <p>Shutter open</p> <p>Strobe, fast → slow</p> <p>Shutter open</p> <p>Opening pulse, fast → slow</p> <p>Closing pulse, fast → slow</p> <p>Shutter open</p> <p>Random strobe, fast</p> <p>Random strobe, medium</p> <p>Random strobe, slow</p> <p>Shutter open</p> <p>Random opening pulse, fast</p> <p>Random opening pulse, slow</p> <p>Random closing pulse, fast</p> <p>Random closing pulse, slow</p> <p>Shutter open</p> <p>Reset fixture</p> <p>Shutter open</p> <p>Lamp on</p> <p>Shutter open</p> <p>Lamp off</p>	
	2	2	0 - 255	0 - 100	<p>Dimmer</p> <p>Closed → open</p>
		3	0-255	0-100	<p>Dimmer fine (Least Significant Byte)</p> <p>Closed → open</p>
			0 11 22	0 4 9	<p>Color</p> <p>Continuous Scroll: full color positions:</p> <p>White</p> <p>CTC</p> <p>Yellow 603</p>

The bold numbers down the left are the DMX offsets for the attributes described under the “function” heading. Notice that the first attribute uses only 1 offset value and so is therefore an 8bit parameter. Attribute 2 (Dimmer) can be either 8bit or 16bit depending on the mode selected in the fixture itself. If you are using 16bit mode then the dimmer uses offset 2 and 3.

To create a new fixture click on the “New Fixture” button at the top left of the fixture editor. The “Add Fixture” dialog will appear and can be used to create a blank fixture or a copy of an existing fixture.

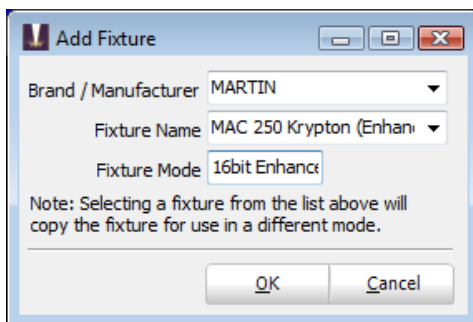

Figure 18: Add Fixture Dialog

The “Manufacturer” field will automatically be populated with the current brand you have selected. You can either choose a different manufacturer from the drop down list or enter a new name directly into the field.

If a fixture is chosen from the drop down list then the resulting new fixture will be a copy of that one selected. All of the attributes contained in that fixture will be automatically setup. If a new name is entered into the name field then the fixture created will be blank and have no attributes.

If you are making a copy of an existing fixture you must enter a mode description different to the one that currently exists. If this is a blank fixture the mode is optional.

You can click on the cancel button at any time to return to the fixture editor.

Click on the OK button to create the new fixture. The new fixture will automatically be selected and become the active fixture in the right hand side of the main window.

Figure 19 shows an example of how the first 3 attributes look for the Martin MAC 250 Krypton shown in the chart above.

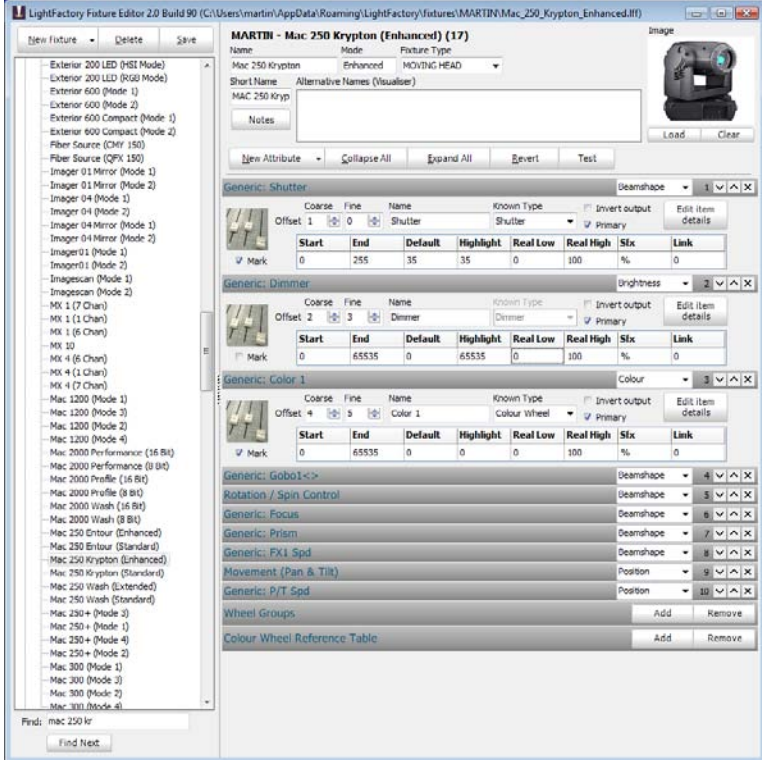

Figure 19: New fixture example

OTHER OPTIONS

IMPORTING FIXTURES

Using the drop down menu on the right of the “New Fixtures” button you can select to import fixtures from either a LightFactory fixture file or a Zero88 fixture file.

After selecting “Import” a standard windows file selection dialog will appear. Use this to locate the file you wish to import and click “Open”.

If you selected a Zero88 fixture file you will see a progress window as LightFactory imports the information into the system.



Note: The fixture import will not overwrite any fixtures that have been modified. If you want to overwrite a modified fixture you must remove it from the fixtures directory in the LightFactory users directory.

If the selected file is a LightFactory fixture file it will be copied into the fixtures directory and loaded into the active library.

DELETING A FIXTURE

To remove a fixture or manufacturer from the system select it in the tree structure on the left hand side of the editor window and press the “Delete” button.

A dialog will warn you of the fixture you are about to delete. To confirm the deletion click on the “Yes” or to cancel select “No”.

SAVE

All modifications to fixtures must be saved before they will take effect in LightFactory. As soon as a fixture is modified the save button will become active. You can save your changes at any time in the editing process. If the edit button is not active then there is no changes requiring to be saved.

After the fixture has been saved a message will be sent to LightFactory and the fixture library reloaded. This may cause a small pause in the DMX processing of LightFactory.